

Wire  
Mesh

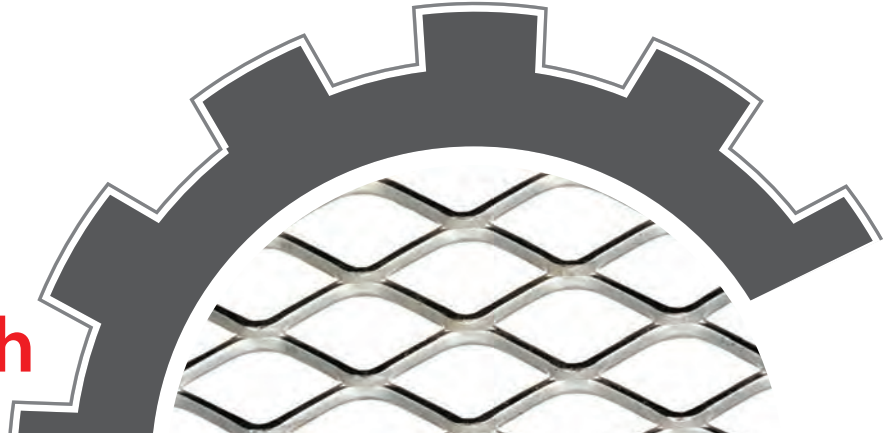

المير للصناعات ALMEER INDUSTRIES



شركة المير للخدمات الفنية ذ.م.م.

Subsidiary of ALMEER TECHNICAL SERVICES CO. W.L.L.



Certificate No. IND 10.4183

008

Cert. No. IND 12.3190/UE

008

# Wire Mesh



**المير للصناعات ALMEER INDUSTRIES**

Almeer Industries established in the year 1997, has been in the business offering a wide range of services in manufacture of Panels for various applications, Street Lighting Poles, Junction Boxes, Cable Trays & Accessories, Unistrut Channels, Wire mesh, Expanded metal, Profiled Sheets, Galvanizing works etc. for Oil & Gas, Petrochemical, Power and other major industries in Kuwait.

Almeer Industries is located in Amghara Industrial Area with modern machineries and equipments. The workshop is located on 10,000 Sq.mtrs of area which consists of Overhead Office, Stores and well laid down area for fabrication, machine shop, CNC Operation, Lighting Pole Machinery, Industrial blasting, Power coating plant, Hot-dip galvanization plant and computerized, manual & chemically etched engraving facilities. The workshop is equipped with overhead crane for material handling and other maintenance services.

We are an ISO 9001: 2008, ISO 14001: 2004 & ISO 18001: 2007 Certified Company with standardization worked into all facets of its work and stride to provide reliable, highest quality and economic solutions to our customers. As we continue to build and strengthen our partnership, we are committed to achieve 100% customer satisfaction and earn your trust and loyalty.

BASKET CABLE TRAY

WELDED WIRE MESH

EXPANDED METAL MESH

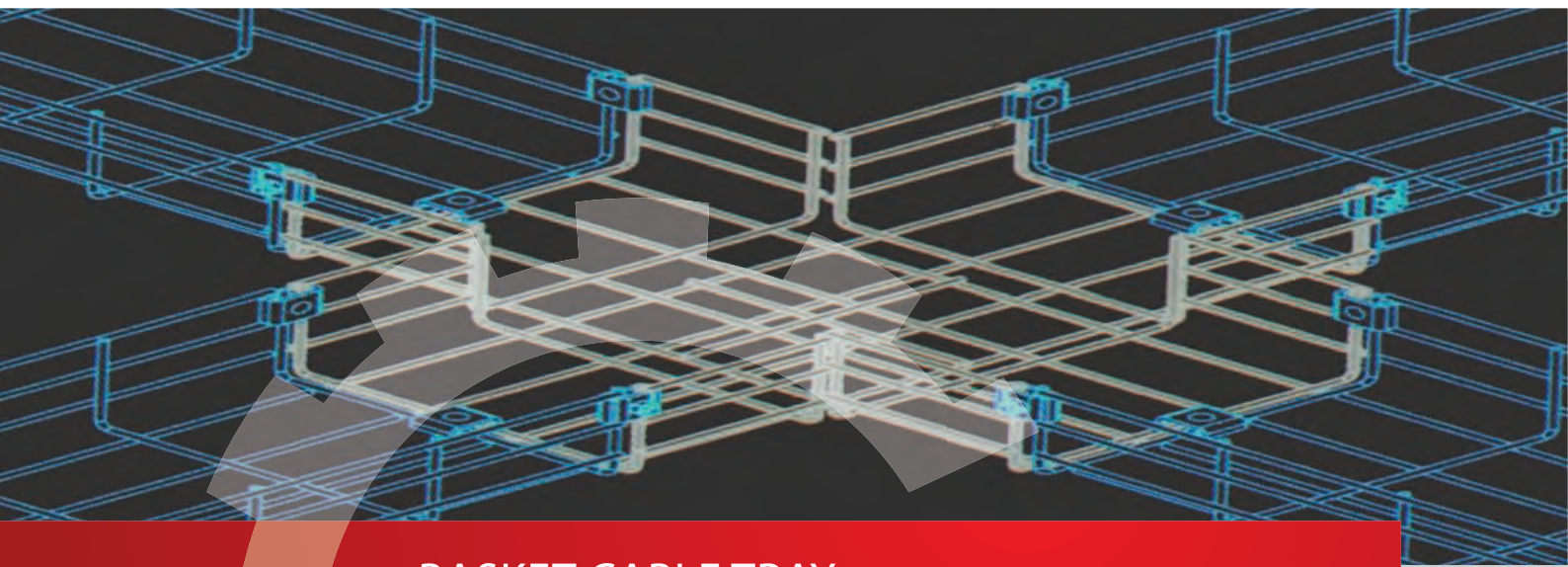

## BASKET CABLE TRAY

In the electrical wiring of buildings, a cable tray system is used to support insulated electric cables used for power distribution and communication. Cable trays are used as an alternative to open wiring or electrical conduit systems, and are commonly used for cable management in commercial and industrial construction. They are especially useful in situations where changes to a wiring system are anticipated, since new cables can be installed by laying them in the tray, instead of pulling them through a pipe.

BASKET CABLE TRAY	PROPERTIES
Type of Material	Mild Steel
Type of Finish	Hot Dipped Galvanized or Black
Type of Usage	Electrical Cable Trays

BASKET CABLE TRAY	SIZE OPTIONS				
	Width (mm)	Length (m)	Opening (mm)	Height (mm)	Thickness (mm)
	100 up to 1000	2	50 x 50 Up to 200 x 200	60 up to 200	4 up to 6

## DETAILED DRAWING



PRODUCTION



## WELDED WIRE MESH

Welded wire or "Weldmesh" is an electric fusion welded prefabricated joined grid consisting of a series of parallel longitudinal wires with accurate spacing welded to cross wires at the required spacing. Machines are used to produce the mesh with precise dimensional control.

The welded wire mesh is a metal screen that is made up of low carbon steel wire or stainless steel wire. It is available in various sizes and shapes. It is widely used in agricultural, industrial, transportation, horticultural and food procuring sectors. It is also used in mines, gardening, machine protection and other decorations. Weldmesh is the term given to the kind of barrier fencing that is manufactured in square or rectangular mesh from steel wire, welded at each intersection. It is usually affixed to steel uprights and sometimes used in reinforced concrete, notably for slabs.

There are several types of welded wire mesh which can be categorized according to their structure, use and characteristics. Observe in the table below the Welded Mesh properties manufactured at Almeer Industries Facilities:

WELDED MESH	PROPERTIES
Type of Material	Mild Steel
Type of Finish	Hot dipped galvanized or Black
Type of Usage	Concrete reinforcement, fencing, basket cable tray, partitions, machine guard, architecture etc

### SPECIFICATIONS:

- Standard Mesh for Concrete Reinforcement.
- The production of Mesh Reinforcement (Deformed & Plain) wire according to (BS 4482/SAE 1008) or equivalent.



WELDED TYPE WIRE MESH	SIZE OPTIONS FOR PLAIN SHAPE			
	Max Width (m)	Max Length (m)	Opening (mm)	Wire Dia. (mm)
	2	5	50x50 Up to 200x200	2.5 up to 8
	SIZE OPTIONS FOR DEFORMED SHAPE			
	Max Width (m)	Max Length (m)	Opening (mm)	Wire Dia. (mm)
2	5	50x50 Up to 200x200	5 up to 8	



## EXPANDED METAL MESH

Expanded metal is a form of metal stock made by shearing a metal plate in a press, so that the metal stretches, leaving diamond-shaped voids surrounded by interlinked bars of the metal. The most common method of manufacture is to simultaneously slit and stretch the material with one motion. Expanded metal is also referred to as perforated metal. It is a large part of the metal industry and plays a key role in metal fabrication.

Expanded metal is used in grates and in outdoor furniture (e.g. benches) or fencing. It is often used for guarding to prevent contact with hot surfaces or machinery. Expanded metal is often used for architectural details and finds use in security applications such as in the walls of a Sensitive Compartmented Information facility because, in heavier grades, it is difficult to breach without heavy cutting equipment or explosives.

EXPANDED METAL MESH	PROPERTIES
Type of Material	Mild Steel
Weaving Characteristics	Punched to mesh, allowing it to be strong & ware resistant
Type of Usage	Concrete reinforcement, fencing, basket cable tray, partitions, machine guard, architecture etc

EXPANDED METAL MESH	SIZE OPTIONS			
	Width (m)	Length (m)	Opening (mm)	Thickness (mm)
	2	1 up to 4	Two Options available 10 x 20 or 40 x 60	1 up to 4

### MIDDLE EXPANDED METAL

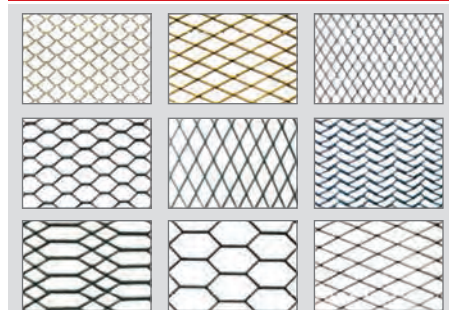

### HEAVY EXPANDED METAL

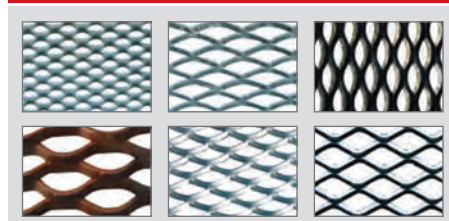

### DETAILED DRAWING

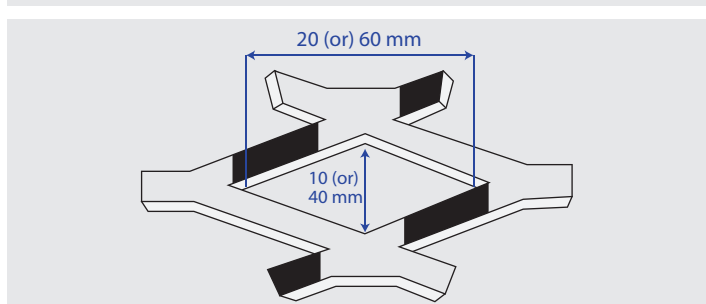
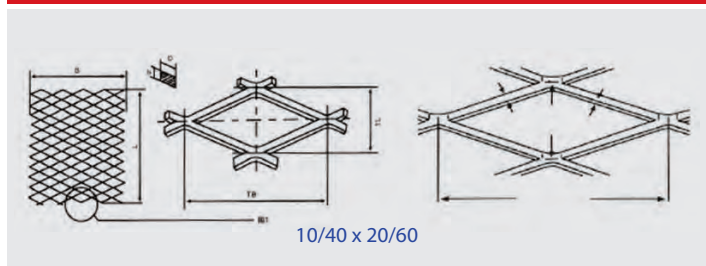



## المير للصناعات ALMEER INDUSTRIES

HEAD OFFICE: P.O. Box 9240 Ahmadi, 61003 Kuwait

Tel. : +965 2398 6594 (10 Lines)

Fax : +965 2398 0682 / 6574

E-mail : [atsco@almeer.com.kw](mailto:atsco@almeer.com.kw)



[www.almeer.com.kw](http://www.almeer.com.kw)

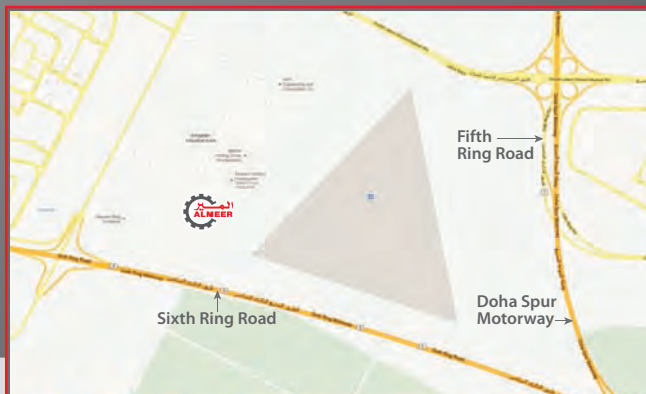

FACTORY: AMGHARA INDUSTRIAL AREA

Tel. : +965 2457 1395 / 4391

Fax : +965 23980682 / 6574

E-mail : [factory@almeer.com.kw](mailto:factory@almeer.com.kw)